



16/24-Port Gigabit Network Switch, 19 Inch, Unmanaged, 2 Uplink Ports, SFP



Quick Installation Guide

DN-95347-2 • DN-95348-2

1. Introduction

The PoE switch offers an outstanding solution for the efficient power supply of network components that support the IEEE802.3af/at standard. With an impressive single port output power of up to 30W, it enables the reliable supply of PoE-enabled devices.

The automatic detection and identification of standard PoE receiving devices makes the power supply intelligent and prevents potential damage from non-standard or conventional devices. By prioritizing the port power supply, the module ensures a continuous power supply for critical network nodes. The panel indicators allow convenient monitoring of the working status and assist in fault analysis. The module also supports VLAN and CCTV functions to maximize flexibility in network applications.

With flow control for full-duplex operation and back pressure for half-duplex operation, the module optimizes data transmission efficiency. Overall, the PoE switch offers a powerful, intelligent and reliable solution for the power supply of network components that meets today's requirements for modern network infrastructures.

2. Features

- Support IEEE802.3af/at Standard
- Single port output power up to 30W
- Automatic detection and identification of standard PoE power receiving devices, intelligent power supply, will not burn non-standard PoE power receiving devices or common devices
- Support port power supply prioritization, guarantee the continuous power supply of key nodes
- Panel indicators monitor working status and help fault analysis
- Support VLAN
- Flow Control for Full Duplex operation and back pressure for Half Duplex Operation
- Support Energy-Efficient Ethernet (EEE) function (IEEE802.3az)

3. Package Contents

- 1x PoE Switch
- 1x User Guide
- 1x Power Cord
- 2x Rack Mount Kit
- 4x Rubber Feet
- 8x Screw

4. Specifications

Model	16-Port Gigabit Network Switch, 19 Inch, Unmanaged, 2 Uplink Ports, SFP	24-Port Gigabit Network Switch, 19 Inch, Unmanaged, 2 Uplink Ports, SFP
Standard	IEEE802.3, IEEE802.3u, IEEE802.3ab, IEEE802.3z, IEEE802.3az, IEEE802.3x, IEEE802.3af, IEEE802.3at	
Network Media	10BASE-T: UTP category 3,4,5 cable (≤100m) 100BASE-TX: UTP category 5 cable (≤100m) 1000BASE-T: UTP category 5e cable (≤100m) 1000BASE-X: MMF, SMF	
MAC Address Table	8K, Auto-learning, Auto-update	
Transfer Mode	Store-and-Forward	
Frame Forward Rate	10Base-T: 14881pps/Port 100Base-TX: 148810pps/Port 1000Base-T/X: 1488095pps/Port	
Switching Capacity	36Gbps	52Gbps
Dimensions (L*W*H)	440*207*44mm	
Fan Quantity	2pcs	
Power Input	AC: 100~240V 50/60Hz	
PoE Port	Port 1-16	Port 1-24
PoE Power On RJ45	Mode A 1/2(+) 3/6(-)	
PoE Power Output	Voltage: 55V DC Power: 30W Max	
PoE Power Budget	250W	370W
Power Supply	260W	400W
Temperature	Operating Temperature: 0°C ~ 40 °C (32 °F ~104°F) Storage Temperature: -40 °C ~ 70 °C (-40 °F ~158°F)	
Humidity	Operating Humidity: 10% ~ 90% non-condensing Storage Humidity: 5% ~ 90% non-condensing	

5. Hardware Description

Front Panel

The following diagram shows the front panel of PoE Switch:

DN-95347-2

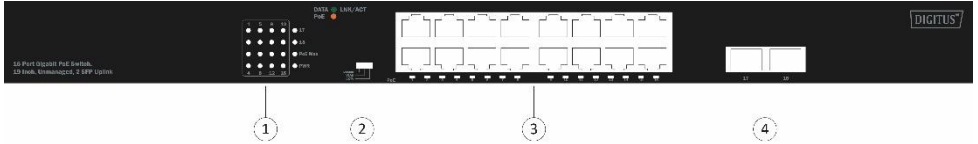

1	LED indicator	2	DIP Switch
3	16x 10/100/1000 Mbps RJ45 Port	4	2x 1000Mbps SFP Slot

DN-95348-2

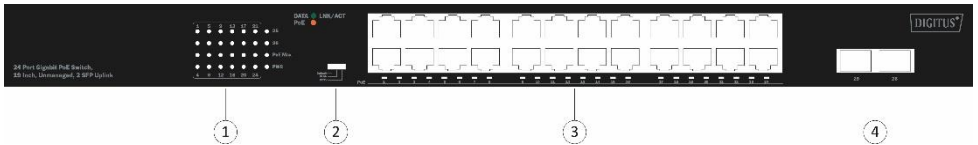

1	LED indicator	2	DIP Switch
3	24x 10/100/1000 Mbps RJ45 Port	4	2x 1000Mbps SFP Slot

DIP Switch: The DIP switch is located on the left panel.

Default: The factory default mode can normal communication between port 1-16 or 1-24.

VLAN: Isolation mode: In this mode, RJ45 ports and SFP ports on the Switch are assigned an independent VLAN. RJ45 ports can only communicate with the SFP ports. RJ45 ports cannot communicate with each other. In this mode, connect SFP ports to the central Switching device.

CCTV: In this mode, RJ45 ports of the switch are isolated from each other, but RJ45 ports can communicate with the SFP ports. If this mode is enabled, ultra-long distance transmission of 250 meters is supported, which can solve the problem of long-distance transmission in network monitoring projects. It can replace optical fibers and network extenders, solve the problem of obtaining power from ultra-remote ends, and reduce the cost of engineering cabling. For DN-95348-2, PD Alive function is only enabled at CCTV mode.

Note: After change the mode, there is no need to restart manually to make the corresponding configuration take effect.

LED indicator

LED	Color	Function
PWR	Green	Off: No Power supply. Light: Indicates the switch has power.
LNK/ACT	Green	Off: No device is connected to the corresponding port. Light: Indicates the link through that port is successfully established at 10/100/1000Mbps. Blink: Indicates that the Switch is actively sending or receiving data over that port.
PoE	Orange	Off: No PoE powered device (PD) connected. Light: There is a PoE PD connected to the port, which supply power successfully. Blink: Indicates port abnormal power supply.

Rear Panel

The rear panel of a switch shows the AC power interface. The power input ranges from 100V AC to 240V AC at 50/60 Hz.

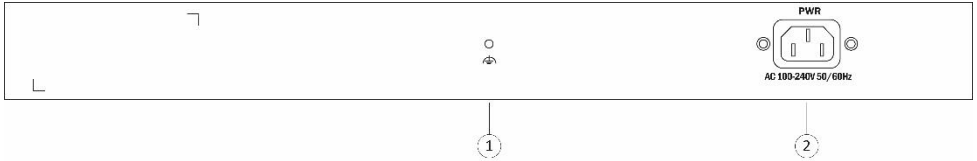

1	Ground Terminal	2	AC power socket
---	-----------------	---	-----------------

Power Socket

This is an AC power socket, connect the negative plug of the power cord to this interface, and connect the positive plug to the AC power supply.

Grounding Column

It is located to the left of the power interface. Please use wire grounding to prevent lightning strike.

6. Installation the Switch

Please follow the following instructions in avoid of incorrect installation causing device damage and security threat.

- Before cleaning the switch, unplug the power plug of the switch first. Do not clean the switch with wet cloth or liquid;
- Do not place the switch near water or any damp area. Prevent water or moisture from entering the switch chassis;
- Do not place the switch on an unstable case or desk. The switch might be damaged severely in case of a fall;
- Ensure proper ventilation of the equipment room and keep the ventilation vents of the switch free of obstruction;
- Make sure that the operating voltage is the same one labeled on the switch;
- Do not open the chassis while the switch is operating or when electrical hazards are present to avoid electrical shocks.

Desktop Installation

Place the bottom of the switch face up on a large enough stable table;

Tear off the attached sticky paper on the surface of the footpad and paste the footpad into the groove at the bottom of the chassis of the switch to prevent external vibration; Carefully position the switch upright on the workbench

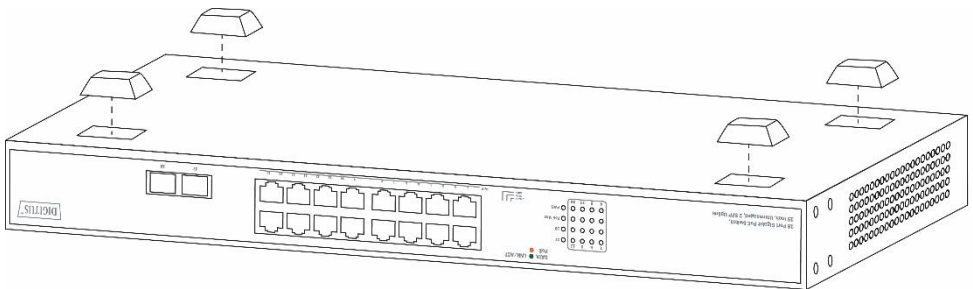

Rack-mountable Installation

To check the grounding and stability of the EIA-19inch cabinet, use screws to fix mounting ears to both sides of the front panel of the switch. Place the switch on a bracket in the cabinet and move the switch along the guide rails to a proper position. Then, use screws to fix mounting ears to the guide rails at both ends of the cabinet. Ensure that the switch is securely installed on the tray in the cabinet slot. The mounting ear of the device is not used for weight bearing, it is only used for fixation. When installing devices in a cabinet, brackets (fixed on the cabinet) are provided below the device chassis to support devices.

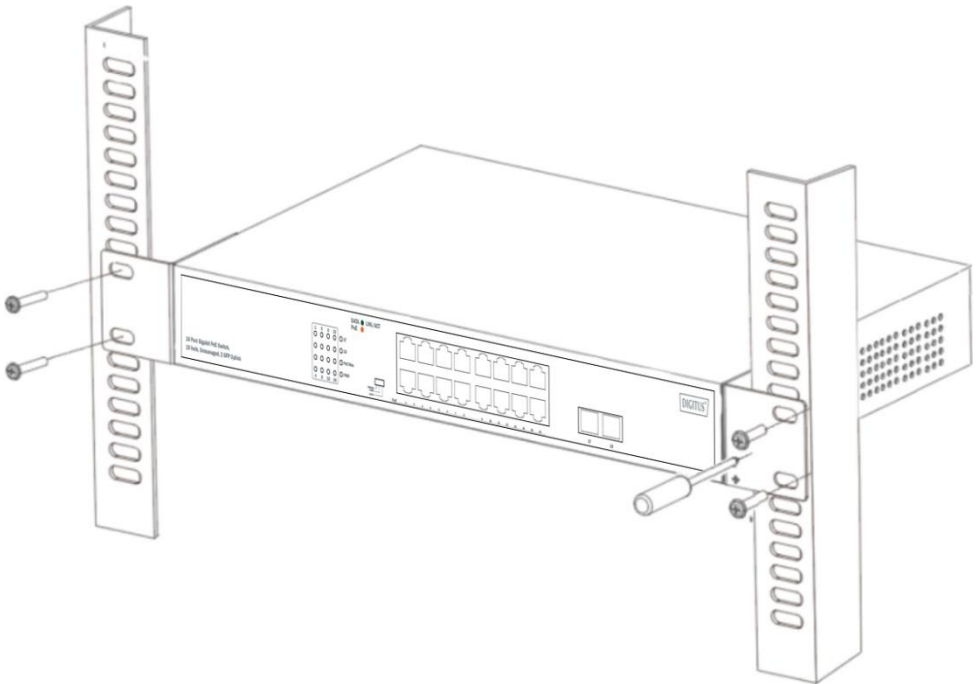
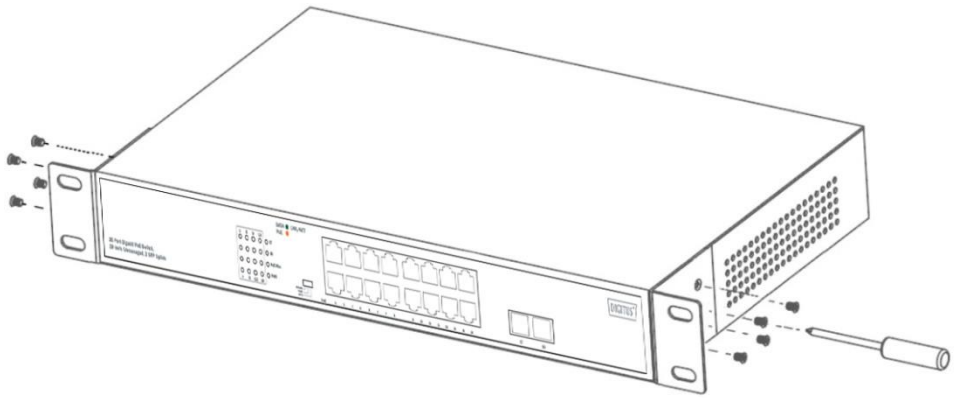

Turn on the switch

Connect the power cord, plug in, and turn on the power. After the switch is started, the switch automatically initializes. If all port indicators are on and off, the system is successfully reset. The power LED indicator is steady on.

Note: Please confirm the voltage is correct before power on, otherwise the switch will be damaged. (The power input is:100V-240Vac, 50/60Hz.)

CE Mark Warning: This is a Class A product. In home environment, this product may cause radio interference. In this case, the user may be required to take appropriate measures.

Hereby Assmann Electronic GmbH, declares that the Declaration of Conformity is part of the shipping content. If the Declaration of Conformity is missing, you can request it by post under the below mentioned manufacturer address.

www.assmann.com

Assmann Electronic GmbH
Auf dem Schüffel 3,
58513 Lüdenscheid,
Germany

