



10/100base-TX to 100base-FX Media Converter



Quick Installation Guide

DN-82010-1_DN-82020-1_DN-82021-1

Table of contents

1. Overview.....	3
2. Check List.....	3
3. Technical Specifications	3
4. Installing the Converter	4
Standalone unit	4
Slide-in unit.....	4
Wire connection, Front and Side panel	4
Dip Switch Settings for converters.....	5
5. LED Description.....	6
6. Connecting to TP, Fiber Device	6
7. Troubleshooting.....	6

1. Overview

IEEE802.3u Ethernet supports two types of media for network connection such as 10/100base-TX and 100base-FX. The bridge media converter designed with a switch controller and buffer memory that connects two types of segments operation smoothly. This converter can be used as standalone unit or as slide-in module to the 483mm (19”) converter rack Chassis for use at a central Wiring closet.

2. Check List

Before you start installing the Converter, verify that the package contains the following:

- The TP-Fiber Converter
- AC-DC Power Adapter (for external models) or Power Cord (for internal models)
- the User's Manual

Please notify your local sales distributor immediately if any of the mentioned items is missing or damaged.

3. Technical Specifications

Standards	IEEE802.3, IEEE802.3U, 10/100Base-TX 100Base-FX
Media Support	10Base-T: Cat 3, 4, 5 UTP/STP, max 100m 100Base-TX: Cat5 UTP/STP, max 100m Multi mode: (50/125um, 62.5/125µm) Single mode: (9/125µm)
TP Connector	SC/ST/FC
Referenced Transmission Distance	Dual-fiber multimode: 2km Dual-fiber singlemode: 20 / 40 / 60 / 80 / 100 / 120km Single-fiber singlemode: WDM 20 / 40 / 60 / 80km
Data Forward Rate	10Mbps/ 100Mbps
Flow Control	IEEE802.3x flow control for full-duplex model Back-pressure flow control for half-duplex mode
Power Supply	5VDC or 110 ~ 260VAC or 48VDC
Power Consumption	2.5W
Operation Temperature	0°C-60 °C
Relative Humidity	5% to 80 % (non-condensation)
Feature	
<ol style="list-style-type: none"> 1. Built in 2-port switch: <ul style="list-style-type: none"> • Supports modified cut-through frame forwarding for low latency • Supports pure converter mode data forwarding for extreme low latency • Supports flow control for full and half duplex operation 	

- Bandwidth control
 - Forward 1600 bytes packet for management
2. Supports 100Base-FX standard
 3. Built in 128KB RAM for data buffer
 4. Supports Auto MDI-MDIX function
 5. Supports link fault pass through function (LFP)
 6. LED display for link/activity, full/half, 10/100M

4. Installing the Converter

Standalone unit

- Verify the AC-DC adapter conforms to your country AC power requirement and insert the power plug.
- Connect the media cable for network connection.

Slide-in unit

- The slide-in Media Converter and Converter Rack Chassis should be supplied only from the same source, both Media Converter Rack Chassis are built to match each other at dimension, DC jack, DC receptacle and power safety.
- Turn off the 483mm (19") converter rack power.
- Ensure that there is No activity in the network.
- Locate +5V DC power jack on converter back, carefully slide in and plug to 483mm (19") rack +5V DC power receptacle.
- Connect the media cable for network connection.
- Turn on the converter rack power, the Power LED Will light up.

Fiber Port	Attach the fiber cable, the TX, RX fiber cable must be paired at both ends. Default: Full duplex mode
Fiber Port	Attach TP Cat. 5 cable to TP Port

Wire connection, Front and Side panel

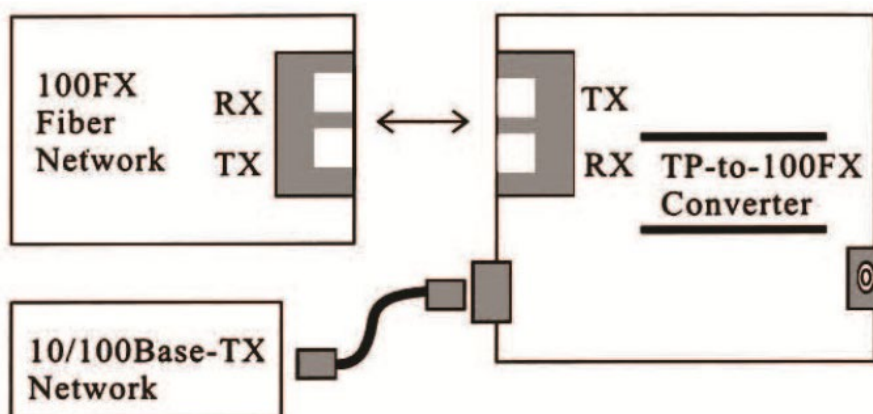

Fig 1 Basic Network Connection

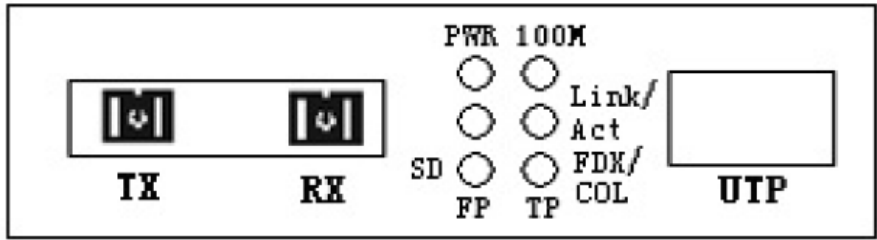

Fig 2: Front Panel for dual fiber media converter

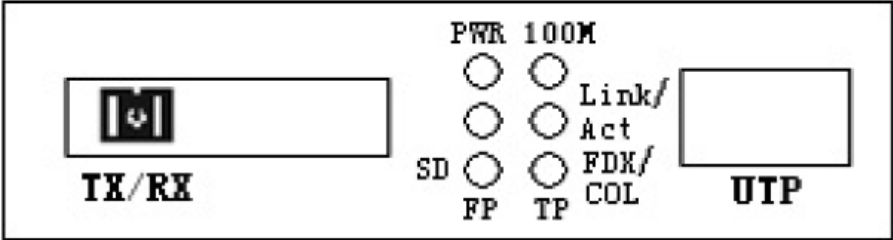

Fig 3: Front panel for single fiber media converter

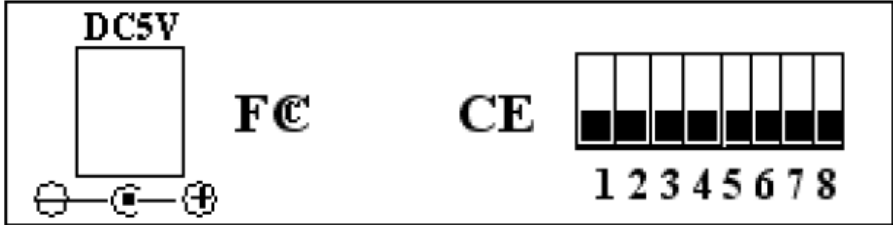

Fig 4: Back panel for single/dual fiber media converter

Dip Switch Settings for converters

No.	Function	Description
1	LFP	ON: Link fault passthrough OFF: LFP disabled
2	Direct Wire	ON: Pure converter mode OFF: Store and Forward Switch
3	Fast FWD	ON: Fast Forward disabled OFF: Fast Forward enabled
4	TP-Force	ON: Force TP speed OFF: 10/100M Auto negotiation
5	IEEE 802.3x	ON: IEEE802.3x disabled OFF: IEEE802.3x enabled
6	Speed_Mode	ON: 10M OFF: 100M
7	Duplex_Mode	ON: TP Port half duplex OFF: TP Port full duplex
8	FX-Full	ON: Fiber Port half duplex OFF: Fiber Port full duplex

5. LED Description

LED indicator	Status	Description
FX Link/Act	On	Connection status display for Fiber Link. "ON" indicates that Fiber link is in correct connection
	Blink	Active status display of fiber link. "Blink" indicates packet goes through FX end
TX Link/Act	On	Connection status display for electric link. "ON" indicates that electric link is in correct
	Blink	Active Status display of fiber link. "Blink" indicates packet goes through TX end
FDX	On	Transceiver works in the full duplex mode
	Off	Transceiver works in the half duplex mode
PWR	On	Power is on and normal
SD	On	Fiber signal is detected
100M	On	Transfer rate of electric interface is 100Mbps
	Off	Rate of electric interface is 10Mbps

6. Connecting to TP, Fiber Device

Converter TP Port 10/100TX	Default: 10/100Mbps Nway <ul style="list-style-type: none"> • Auto-negotiation for Nway TP partner • Half-duplex for non-Nway TP partner, Class II hub, or 10Base-T device
Converter Fiber Port 100FX	100Mbps with duplex mode selectable: <ul style="list-style-type: none"> • Full-duplex for 100Fdx fiber link partner • Half-duplex for 100Hdx fiber link partner FX duplex mode slide switch locates on the rear panel

7. Troubleshooting

If the media converter fails, isolate and correct the failure by determining the answers to the following questions and then taking the indicated action:

1 Is the power LED on the media converter illuminated?

NO

- Is the power adapter the proper type of voltage and cycle frequency for the AC outlet?
- Is the power adapter properly installed in the media converter and in the outlet?
- Contact your local sales distributor for technical Support.

YES - Proceed to step 2.

2 Is the Duplex/Link LED illuminated on a port with twisted-pair cable installed?

NO

- Check the copper cables for proper connection.

YES

- OFF = The media converter has selected half-duplex mode.
- ON = The media converter has selected full-duplex mode.
- If the mode is not correct, disconnect and reconnect the twisted pair cable to restart the initialization process.

Proceed to step 3.

3 Is the “Link action” LED illuminated on the fiber cable port?

NO

- Check the fiber cables for proper connection.
- Verify that the TX and RX cables are connected to the RX and TX ports, respectively, on the 100Base-FX device.

YES - Proceed to step 4.

4 Is the “Speed” LED illuminated on a port with twisted-pair cable installed?

NO

- Check the copper cables for proper connection.

YES

- OFF = The media converter has selected 10Mbps operation.
- ON = The media converter has selected 100Mbps operation.
- If the speed is not correct, disconnect and reconnect the twisted pair cable to restart the initialization process.

Note: Connecting to Router, Bridge or Switch, please refer to the device’s Technical Manual.

Hereby Assmann Electronic GmbH, declares that the Declaration of Conformity is part of the shipping content. If the Declaration of Conformity is missing, you can request it by post under the below mentioned manufacturer address.

www.assmann.com

Assmann Electronic GmbH
Auf dem Schüffel 3
58513 Lüdenscheid
Germany

