



Charging Trolley for Notebooks / Tablets up to 14 / 15.6 inch



Manual

DN-45000, DN-45002

Product Description

The mobile charging cabinet from DIGITUS® is the ideal and compact solution for storing and charging your portable devices such as notebooks and tablets. Mobile charging cabinets are frequently used in public facilities such as schools in order to store devices securely at a central location while charging them at the same time. The cabinet includes 3 rows with 10 charging stations each, all of which have their own USB connection on the front. The devices can also be connected with installed socket strips (3 x 10 safety sockets) at the back. Thanks to ample cable feedthroughs and excess cable storage, optimal cable management is guaranteed. Installed ventilators (3 x 24 V) combined with ventilation slits ensure active cooling of the cabinet.

Technical Features

- Double Folding Front and Back Door
- Pressure lock system with swiveling lever handle on the front and back door, lockable
- 180° door opening angle
- 2-point locking (rod lock)
- Incl. 4 rollers (2 lockable)
- Including handles for better mobility (enclosed)
- Product dimensions DN-45000 (H x W x D) in mm: 1100 x 700 x 600 mm
- Product dimensions DN-45002 (H x W x D) in mm: 1100 x 700 x 650 mm
- Safety plug socket (AC) with switch on the side
- C20 connection on the side
- Incl. RCD 30 mA (residual current operated device)
- Delivery is completely assembled
- Depth of inner tray (DN-45000): 315 mm (suitable for up to 14" devices)
- Depth of inner tray (DN-45002): 415 mm (suitable for up to 15.6" devices)

Package content

- Mobile charging cabinet
- 2 x handle (for installation on outside) including mounting material
- Power cable

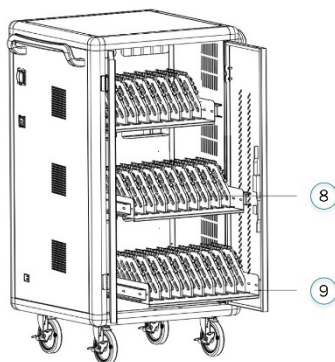
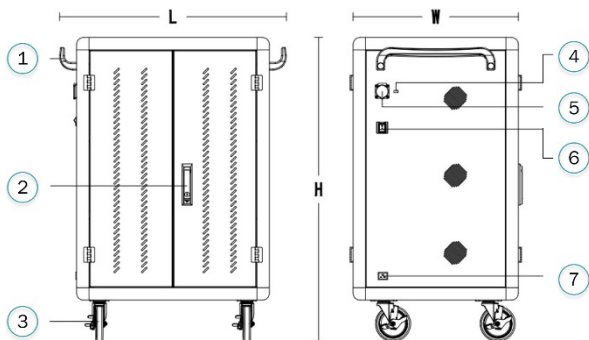

- 1) Handle
- 2) Handle with lock
- 3) Super silent universal brake casters
- 4) External USB outlet
- 5) External output socket
- 6) Power switch
- 7) Power input port
- 8) Plastic separator
- 9) Drawer (optional)

Service Environment

| | |
|--|-------------|
| Working temperature | 0°C~45°C |
| Working environment humidity | 20%~80% |
| Humidity of storage environment | -15°C ~45°C |
| The machine has passed the national CCC certification, CE certification and RoHS certification | |

Product Parameter

| | |
|----------------------------|---|
| Main material | The main body adopts 1.0mm-1.5mm cold-rolled steel plate, the main frame adopts high strength aluminum profiles, the cabinet is provided with ABS engineering plastic partition layer, a layering the tablet is effective in preventing scratches |
| Input | Alternating current AC 110V/220V, 50/60Hz, 16A |
| Product power | 3500W |
| Cooling system | Forced air cooling |
| Output | Recharge: 10W/ 5V 2.1A Output: 110V/220V, 50/60Hz, 10A/16A |
| Status indicator light | Red light: in charging state, green light: full/disconnected |
| External AC socket | 1 x safety outlet |
| External USB charging port | 1 |
| System compatibility | Android system, IOS system, Windows system |
| Support protocol | BC1.2, DCP max 5V 1.5A APPLE mode (QC3.0): 5V 1A iPhone 6 below, 5V 2A iPhone 6 above SAMSUNG: 10W protocol, includes BC1.25W protocol |
| Super compatible | Other Android devices, Other mobile terminals, V+/V-No agreement class |

Behaviour of electricity

1. Overload protection: Cut off the power automatically when overloaded, protect equipment
2. Leakage protection: Quick leakage protection device, double leakage protection. Prevent personal electric shock and leakage and ensure safety
3. Insulation blocking: AC and DC isolation design, electrical shield installation, safe low voltage
4. Overcurrent protection: Each port is configured independently to the maximum 3.1A continuous output, discount the failed port output when the load overflows. Don't affect other port usage
5. Input overvoltage protection: When the power input voltage is higher than 30V, intelligent cut off input and output, protect other charging equipment from damage
6. Input undervoltage protection: When the power input voltage is below 8V, intelligent cut off input and output, protect other charging equipment from damage
7. Output short circuit protection: Cut off the output in case of abnormal short circuit of the output port to ensure safety
8. Perfusion protection: Built-in reverse cut-off, prevent equipment current backflow
9. Overcharge protection: Built-in overcharge protection circuit, intelligent detection charging condition of charging equipment, after the completion of charging it will automatically stop charging to realize worry-free charging
10. To use safety as the premise, intelligent control to achieve high-performance, high-quality, charging
11. Efficient heat dissipation: The design of air flow heat dissipation channel with lower intake and upper exhaust is adopted to effectively improve the heat dissipation effect
12. Industrial concentrator charging: more in line with public charging than the original civil charger
13. To provide a high-quality use environment
14. The integrated circuit: Built-in MCU+ intelligent chip integrated circuit (DS dual intelligent charging)
15. Automatically turn lights: Multicolor status indicator, automatically displays current port device status
16. The temperature control: When the temperature in the cabinet exceeds 40°C, start the cooling fan to dissipate heat quickly and ensure safe charging
17. Auto sleep: Automatic sleep without charging device, reduce power consumption, intelligent ring charging

18. Auto sleep: Automatic sleep without charging device, reduce power consumption, intelligent ring charging
19. Wide voltage input: Support global 100~264V wide voltage input (optional)

Other characteristics

Details make for a better user experience

1. Mute design: Adopt silent silicone universal wheel and cLOCKED variable speed cooling fan, greatly reduce noise generation
2. Neat: Gate array mode, beautiful and tidy, projected status indicator light, at a glance

Ergonomic: Plastic partition bracket, arc edge design, self-braking function

Mistake proofing design: Users need not care the equipment always works at its best

USB Charging operation

1. Disconnect the charger in advance and open the cabinet door.

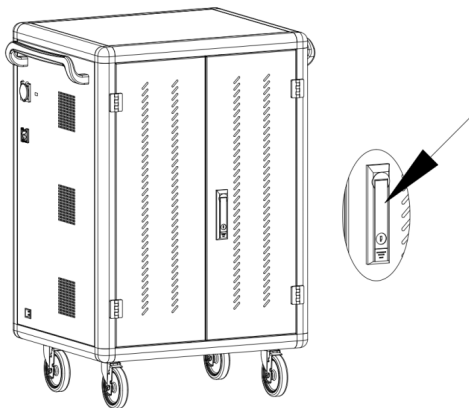

2. According to the tablet number, put the tablets one by one into the tablet rotation slot corresponding to the number

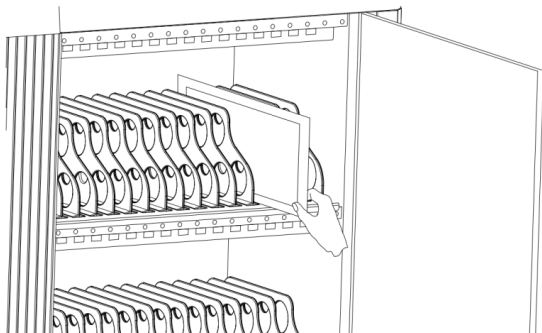

3. The two ends of the USB cable are connected to the charging HUB port on the device and the tablet port respectively

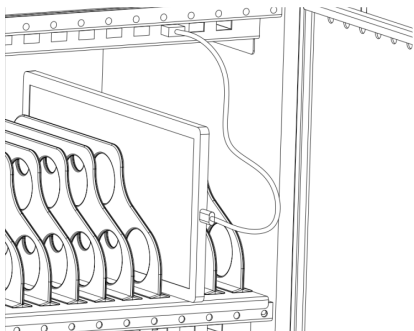

4. After the connection is completed, lock the cabinet door and plug the power plug of the charging car into the mains outlet for charging

5. Switch the main power switch to "ON", and then all charging units' LED charging status indicator lights up red, and the device is in charging state

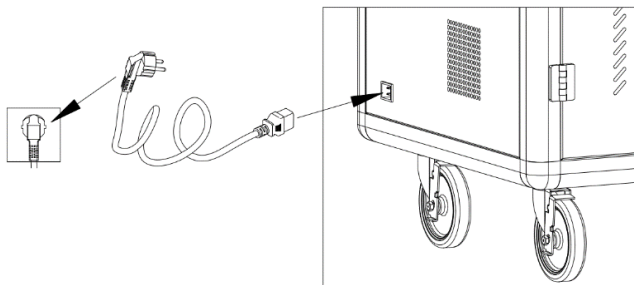

Charging operation with adapter

6. Disconnect the charger in advance and open the rear door

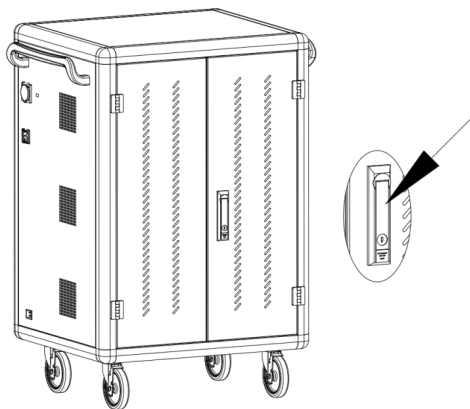

7. Plug your tablet or laptop charger into the socket at the back of the car one by one, then thread the cable through the hole. For laptop charges, place the adapter in the bucket below the thread hole

Laptop adapter
(optional) can be
placed here.

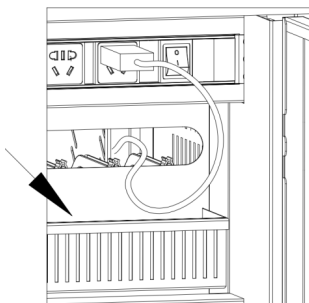

8. Open the front door of the charging car

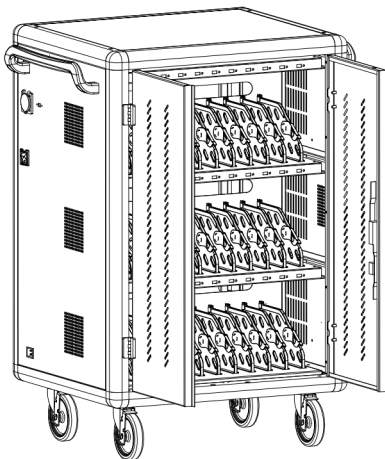

9. Jam the data line with the buckle and arrange the data line

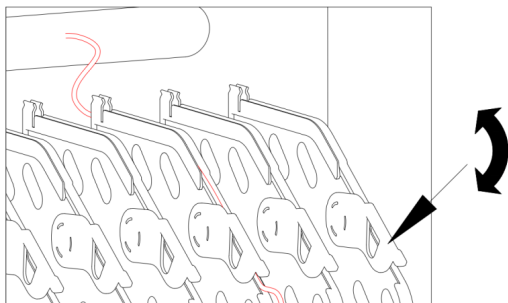

10. Place tablets or laptop one by one in the tablet (laptop) slot and connect to the corresponding data cable

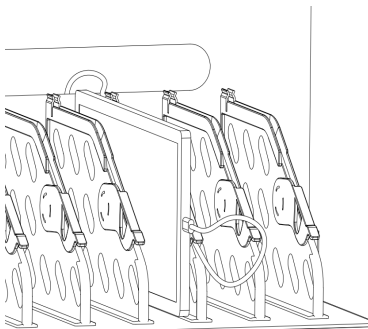

11. After the connection is completed, lock the cabinet door and plug the power plug of the charging car into the mains outlet for charging

12. Switch the main power switch to “ON” and then all charging units are in charging state

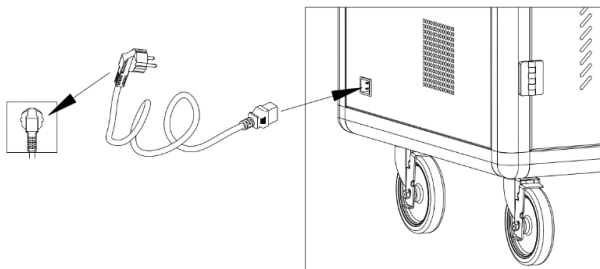

Safety and Grounding:

Read the following information before installing or operating your DIGITUS Charging Trolley with built-in Power Distribution Units:

- This PDU is intended for indoor use only.
- This PDU must not be operated one behind the other!
- Operation only in dry and closed rooms.
- This PDU may not be operated covered. Always ensure free accessibility.
- The PDU may only be used with a max. 16 A fused AC outlet.
- The maximum power stated on the rating plate must not be exceeded.
- Plug this PDU into a three-wire, grounded power outlet only. The power outlet must be connected to appropriate branch circuit/ mains protection (fuse or circuit breaker). Connection to any other type of power outlet may result in a shock hazard.
- Check that the power cord, plug, and socket are in good condition.
- Voltage free only when the power plug is unplugged.
- Disconnect the PDU from the power outlet before you install or connect equipment. Reconnect the PDU to the power outlet only after you make all connections. If external damage to this PDU is detected, do not operate this PDU. Take this PDU immediately out of service if external damage is detected.
- Operation under unfavorable environmental conditions must be avoided. (Humidity over 80% relative, wet, ambient temperatures above 50 ° C, solvents, flammable gases, dust, vapors).
- Do not pour liquids over the power strip. There is a high risk of fire or life-threatening electric shock.
- When opening the power strip, live parts can be exposed. There is a risk of electric shock. The power strip may only be opened by a specialist. When opening the power strip, live parts can be exposed. There is a risk of electric shock. The power strip may only be opened by a specialist.

Declaration

Hereby Assmann Electronic GmbH, declares that the Declaration of Conformity is part of the shipping content. If the Declaration of Conformity is missing, you can request it by post under the below mentioned manufacturer address.

www.assmann.com
Assmann Electronic GmbH
Auf dem Schüffel 3
58513 Lüdenscheid
Germany

