



# **CHARGER BOX (2x USB A, 1x USB Type-C™)**



## **Quick Installation Guide**

DA-70618 Rev. 2

## 1. Package Content

- 1x Main unit
- 1x User Manual

## 2. Energy Efficiency

Input: 230~, 50Hz, Max 0.3 A

Output: total 5.0Vd.c 3.1A, Max. 15.5 W

### For Type A

- 5.0Vd.c. 2.4, Max. 12.0 W
- Average active efficiency: 82.8 %
- Efficiency at low load (10%): 75.0 %

### For Type C

- 5.0Vd.c. 3.0, Max. 15.0 W
- Average active efficiency: 82.8 %
- Efficiency at low load (10%): 75.0 %

No-load power consumption: 0.09

## 3. Connections

1. Turn power off before installation.
2. Connect the socket as shown in diagram A. Before installing the socket, make sure that no wire is exposed at the connection.

Note that the phases cannot be grounded through another grounded outlet in the vicinity. We recommend installing the grounded outlet at the end of the row.

(ATTENTION: the cross-sectional area of wire connect power is at least  $1.5\text{mm}^2$  not exceed  $2.5\text{mm}^2$ )

3. To fix the base by the screw or claw as Diagram B or Diagram C, then put the frame onto the base.

### 3.1 Cavity wall/ Dry construction

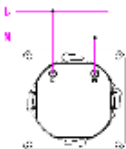

Diagram A

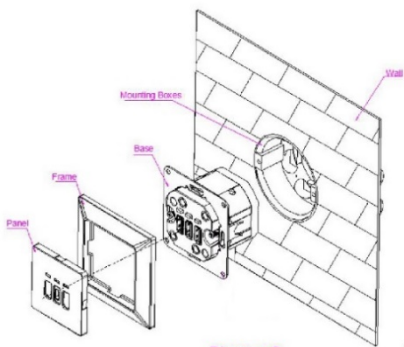

Diagram C

## 3.2 Solid wall (brick)

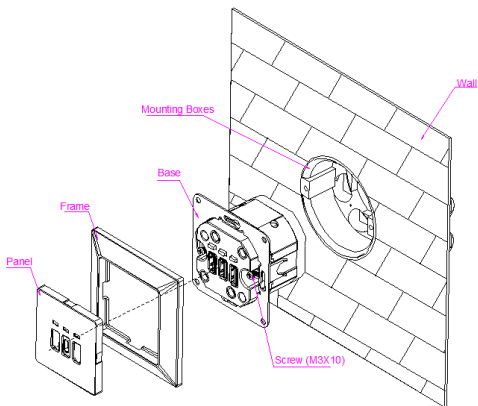

Diagram C

## 4. Explanation of symbols



For indoor use only



SMPS (switch mode power supply unit)



SMPS incorporating a Short-circuit-proof safety isolating transformer (inherently or non-inherently)



Symbol for class II

**PE**

Protective earth



Protective earth

## 5. Warning

The following safety instructions must be observed before use:

1. Operate the device indoors only.
2. Avoid the influence of moisture, dust, sunlight or other sources of heat.
3. The socket outlet is part of the building installation. The relevant national standards and directives must be observed during planning and installation.
4. The appliance may only be operated on the 230V/50 Hz AC mains. Work on the 230V mains may only be carried out by a qualified electrician certified in your country.
5. Observe the applicable accident prevention regulations during installation.
6. To avoid electric shock to the appliance, please disconnect the mains voltage (e.g. switch off the circuit breaker).
7. Failure to observe the installation instructions may result in fire or other hazards.
8. Installation may only be carried out in commercially available

flush-mounted boxes (appliance boxes) in accordance with DIN 49073-1, with a minimum depth of 40 mm.

9. Observe the permissible cables and cable cross-sections when connecting to the device terminals.

**Mandatory information in accordance with the appliance safety standard:**

**Note !**

1. Installation only by persons with relevant electrical knowledge and experience!
2. Improper installation endangers your own life and the lives of the users of the electrical system.
3. Improper installation puts you at risk of serious damage to property. You may be personally liable for personal injury and damage to property.
4. Contact an electrician.



### **Specialist knowledge required for installation:**

The following specialist knowledge in particular is required for installation:

1. the application of the 5 safety rules:
  - a. Disconnect
  - b. Secure against restarting
  - c. Ensure that there is no voltage
  - d. Earth and short-circuit
  - e. cover or isolate neighboring live parts
2. selection of suitable tools, measuring equipment and, if necessary, personal protective equipment.
3. select the electrical installation material to ensure the shutdown conditions.
4. checking the electrical system after installation.
5. observing the IP protection classes
6. installation exclusively with suitable electrical installation material

7. checking and observing the respective specifications for the type of supply network (TN system, TT system or IT system) and the resulting connection conditions (zeroing, protective earthing, or any additional measures required, etc.).

**Maintenance and cleaning:**

1. the socket is maintenance-free.
2. leave any repairs to a qualified electrician.
3. clean the appliance only with a soft, clean, dry and lint-free cloth.
4. do not use cleaning agents containing solvents. This can damage the plastic housing.
5. do not use wet cloths or sponges to clean the appliance.

## Declaration of Conformity

Hereby ASSMANN Electronic GmbH declares that the Declaration of Conformity is part of the shipping content. If the Declaration of Conformity is missing, you can request it by post under the below mentioned manufacturer address.

[info@assmann.com](mailto:info@assmann.com)

Assmann Electronic GmbH

Auf dem Schüffel 3

58513 Lüdenscheid

Germany

