

**ednet.**

# **Spectro II LED Bluetooth<sup>®</sup> Speaker**



**Manual**

33048

## **Important Safety Instructions**

- This speaker is designed to protect against splashing water sprayed at all angles. Dropping the whole unit in body of water may damage the product.
- Keep speaker away from any source of heat.
- Adjust the volume to a suitable level so as to avoid damaging your hearing, or the unit itself.
- If you do not use the speaker for a long time, please charge and discharge at least once a month, in order to prevent the lithium battery from damages caused by excessive consumption.

## **Features**

### **1. Five Multi-colored LED Themes**

Full spectrum light themes matching with your music

### **2. Bluetooth® Music play, BT 4.0 Version**

Bluetooth® 4.0 stereo music playing

### **3. NFC (Near Field Communication)**

One touch easy pairing with your NFC Smartphone

### **4. Mobile Hands-free Function**

Support mobile hands-free communication

### **5. AUX IN**

Enable the device work as an external speaker by connecting to the audio source of computer, mobile, PSP/MP3/MP4 etc.

### **6. USB Sound Card**

USB Sound Card, charging functions can be achieved via the same USB cable

## **Technical Data**

Voltage	DC 5V	Aux In	3.5mm
Output	4W	N.W	235g
Impedance	4Ω	Size	90.0 × 90.0 × 46.5mm







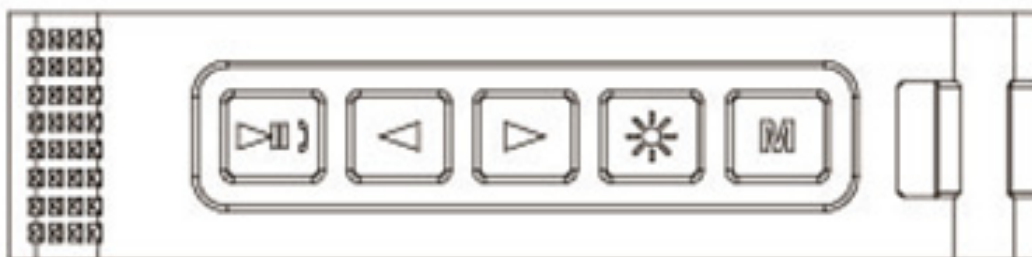

## Package Contents

- Speaker
- USB cable, 3.5mm audio cable
- Manual
- Strap

## SLOT AND KEYS

### A. KEYS



-  1. Short press: Pause/Play/Mute/Hang off/Answer the Call  
Double click: Dial back the last call
-   2. Short Press: Previous/Next song  
Long Press: Volume decrease/increase
-  3. Short Press to Switch the LED Themes
-  4. Short Press to change different mode
-  +  5. Reduce the lightness
-  +  6. Increase the lightness

## B. SLOT

Slot

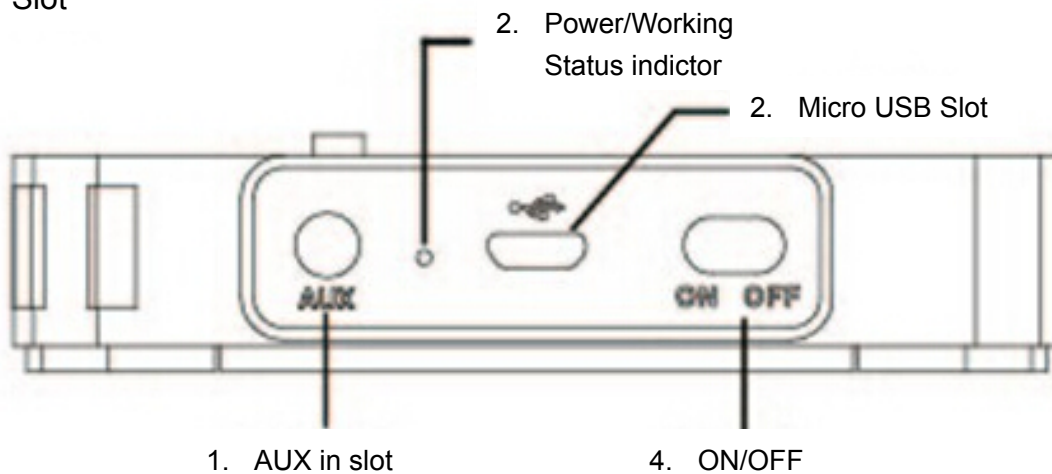

1. **AUX in slot:** Insert 3.5mm audio cable, press  "Aux in mode". The device will work as the external speaker of audio source of computer, PSP/MP4 etc.
2. **Power/Working status indicator:**
  - i. Blue: normal working
  - ii. Orange: charging
  - iii. Flashing orange: low battery
3. **Micro USB Slot:** Connect this slot with computer and enter into USB sound mode. Speaker will be in charging mode.
4. **ON/OFF:** Power on/off

## Instructions

### Power on/off:

Switch the button to power on/off Bluetooth® of the speaker

**Bluetooth® Pairing:** Press  to enter the Bluetooth® mode. Then turn on the Bluetooth function of your mobile/other devices, and start to search for Bluetooth® devices. The "Spectro II" will be found, please connect it. (The speaker will voice "Device paired" when connected successfully).

### NFC function:

(It requires the mobile has NFC function and the speaker is in Bluetooth® mode)

Turn on the mobile's NFC function and make the mobile touch the speaker's NFC area. The mobile will remind you to pair with the Bluetooth® device. Choose yes to complete the pairing.

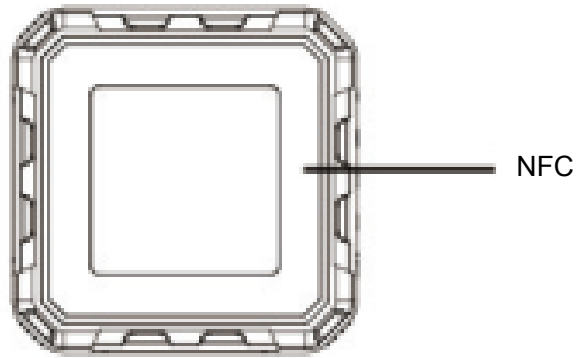

### **Bluetooth®/NFC Music Play:**

Please turn on the mobile or other devices' music player, and speaker will play the selected music.

### **Mobile Hands-free communication:**

#### **① Answer**

Short press  to answer the call.

#### **② Hang off**

Press  again to hang off the call

#### **③ Dial Back**

Double press the  button to dial the last call back

## LED Themes

Short press  to switch the LED themes, there are five different LED themes

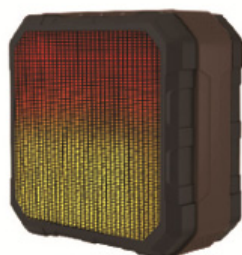

Groove

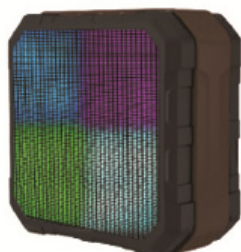

Neon

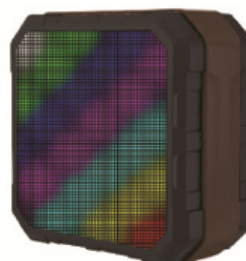

Rainbow

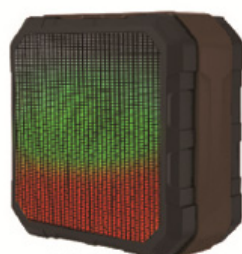

Club

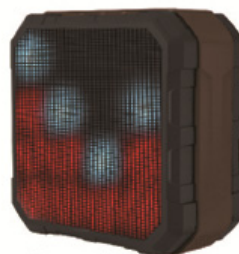

Equalize

## AUX IN

Use the 3.5mm audio cable included to connect the speaker to an audio source (PC, MP3/MP4, mobile phone). Short press the  button to enter “**AUX IN**” mode (the speaker will voice “**AUX IN**” mode). The speaker will play the music from the audio source.

Please note: Low battery will affect the music sound quality, please charge the speaker by adaptor (5V 1A) immediately.

## Charging

The speaker uses a built-in lithium battery. You can use the USB cable included to connect the speaker to the computer or a branded good quality 5V/1000mA adaptor to charge the battery. When charging, the LED indicator is orange, and after finishing the charging, the LED indicator will turn blue.

Please note: (1) Low battery will make the indicator light flash quickly. Please charge immediately. (2) We recommend to charge the speaker with branded adaptor (5V 1A).

## App Download

If you have an Apple® iOS device, then you will find our "ednet.audio" App in the Apple App Store®.

For smartphones and tablets running on Google Android OS you can find our "ednet.audio" App in the Google™ Play Store.

In the search field of the respective App Stores® enter "ednet" or "ednet.audio".

Apple App Store®



Google™ Play

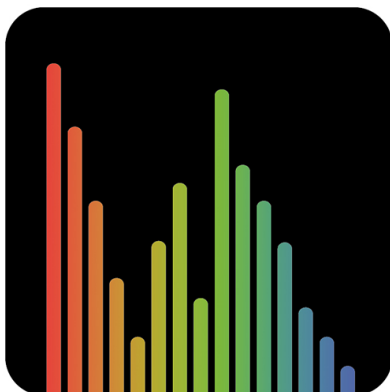
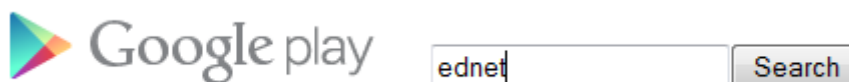

In the Search results the "ednet.audio" App will be marked with this symbol. Then install the App on your mobile device.

## APP Manual



When you connect the ednet Spectro II LED Bluetooth® Speaker with your mobile device via Bluetooth®, the APP will work as below:

### **Settings:**

How to connect your device and play the music via Bluetooth®:

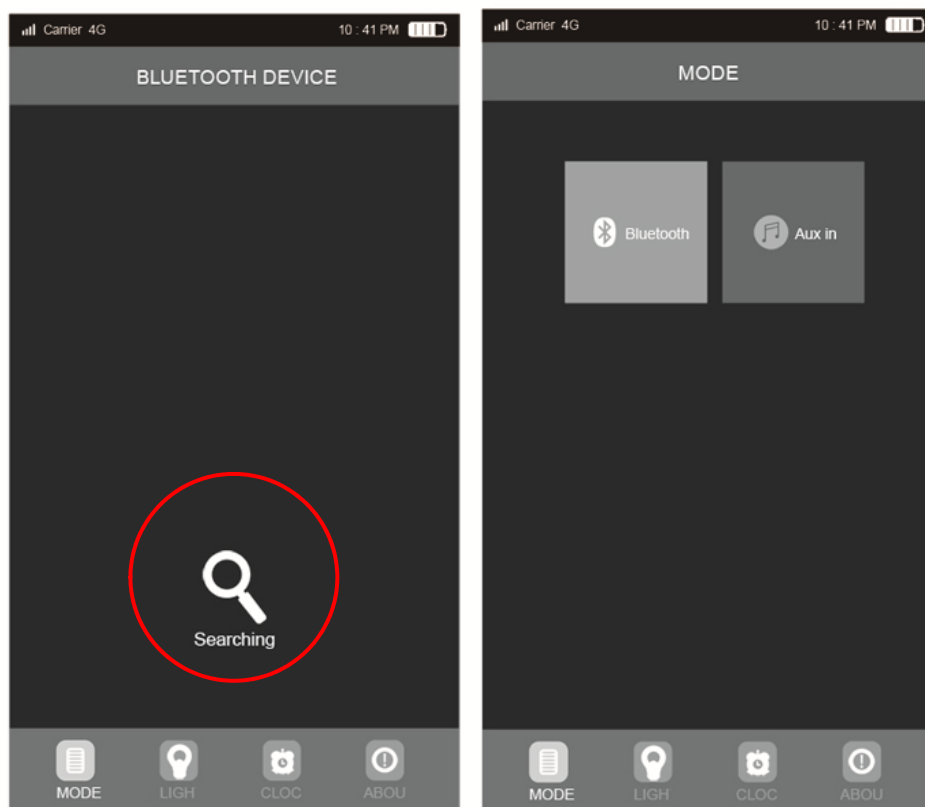

Open “ednet.audio” APP, click “Searching” on the page of “BLUETOOTH® DEVICE” In the list, choose the model name “Spectro II”.



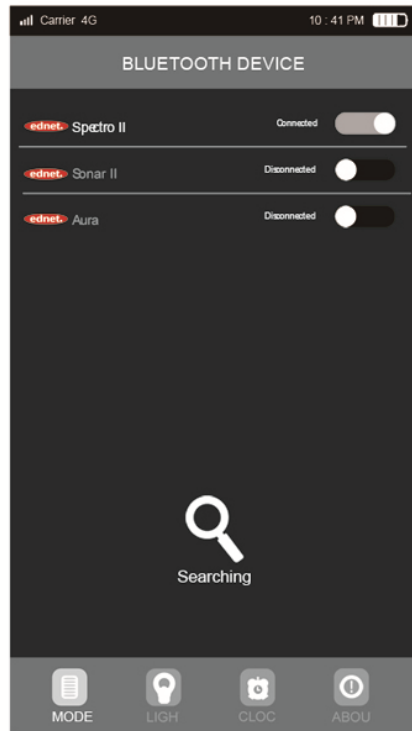

After successful connection, enter the Bluetooth® playing mode, there will be a list of songs in the MP3 format. So click on one of the songs to play, or click the button “Previous”/“Next” to choose another song.

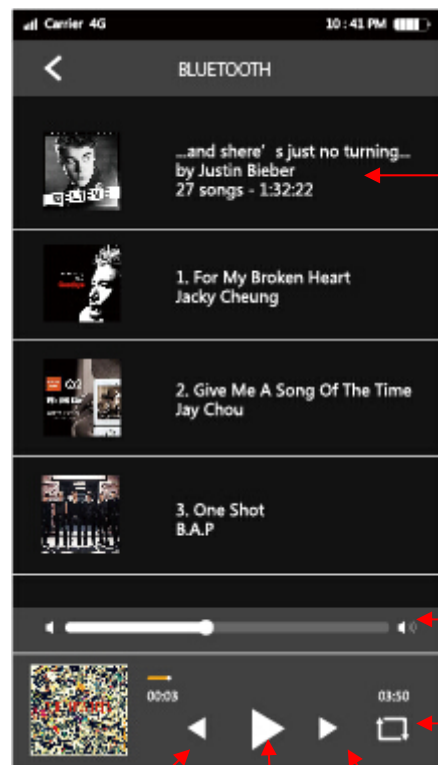

Click the song to play

Volume scrollbar, move it to adjust the volume

Music Playing Mode: Random, Order, Single cycle

Previous

Play/Pause

Next

## How to control the multi-color full spectrum themes

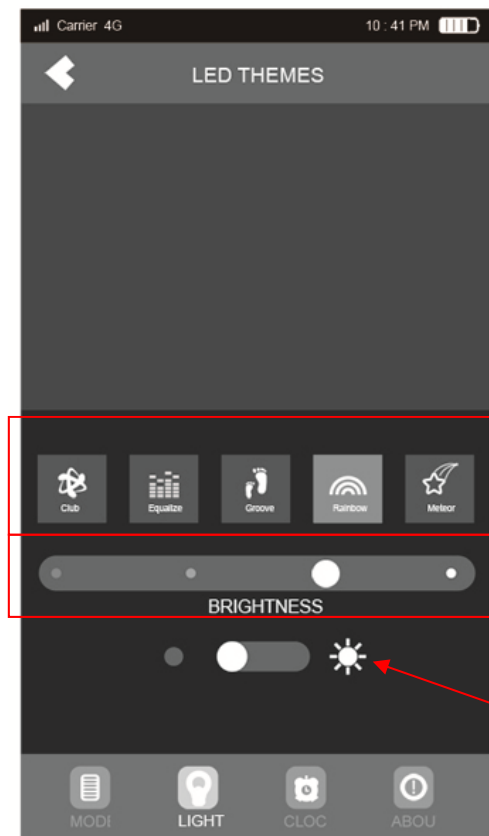

There are five multi-color LED themes, but the first and second one just work when the music is playing

Four levels of brightness: Off, Darker, Middle, Brightest

Turn on/off of the LED light themes

## How to set the alarm

Click the time on the page of "ALARM" to set the time.

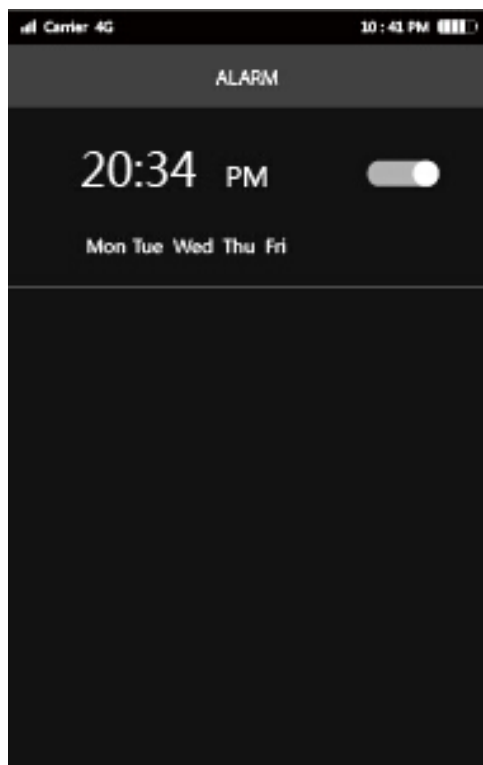

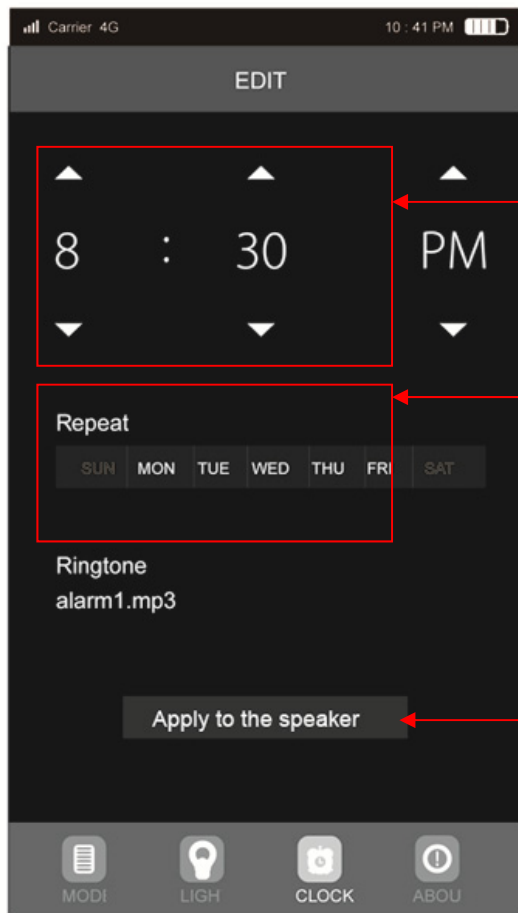

Set the time of alarm

Set the repeat times of alarm

Confirm the alarm to the speaker

## **Troubleshooting**

### **1. What should I do if the speaker cannot pair with the Bluetooth® device and play music accordingly?**

Please check the specification/ the manual of the Bluetooth® device (your mobile or computer), and check if the device can support the A2DP stereo audio transmission. If yes, please turn on the A2DP stereo mode.

### **2. What should I do if the PC USB function could not work?**

- (1) Connect the speaker to the computer via the USB cable included, and enter the PC USB mode. And then play the video/audio from the computer.
- (2) If it could not work, the sound card of the speaker may be incompatible with the computer. Please try to click the device manager - click the Voice video and games controller - right click the USB Audio device - click the uninstall. Then switch the speaker to PC USB mode again. The computer will automatically update the USB sound card drive to achieve the compatibility.

**Please note:** The USB sound card function only apply to Windows XP/Windows vista/Windows 7/Windows 8.

Hereby ASSMANN Electronic GmbH, declares that this device is in compliance with the requirements of Directive 2014/53/EU and the Directive 2011/65/EU for RoHS compliance. The complete declaration of conformity can be requested by post under the below mentioned manufacturer address.

#### **Warning:**

This device is a class B product. This equipment may cause some radio interference in living environment. In this case, the user can be requested to undertake appropriate measures to prevent interference.

**www.assmann.com**

Assmann Electronic GmbH  
Auf dem Schüffel 3  
58513 Lüdenscheid  
Germany

