



# **Industrial Optical Switch**

**User Manual**

## 1. introduction

The Industrial Switch is in an IP40 rugged strong case, Industrial Level-4 EMC design, which can work steady in harsh environments. It is an ideal solution to providing network by supporting Auto-Negotiation and LED indicators.

The device supports redundant power system (12~56VDC) to guarantee the network stability. It is flexible and convenient for two Installation methods: DIN-Rail mounted and Wall-mounted. For PoE version, supporting up to 30W power per port for any remote IEEE802.3af/at powered device (PD) such as PoE IP cameras and PoE wireless LAN access point.

## 2. Package content

Please check the following items in the package before installing the device

Industrial media converter/Switch	1piece
User manual	1copy
DIN-rail or wall mounting kit	1piece

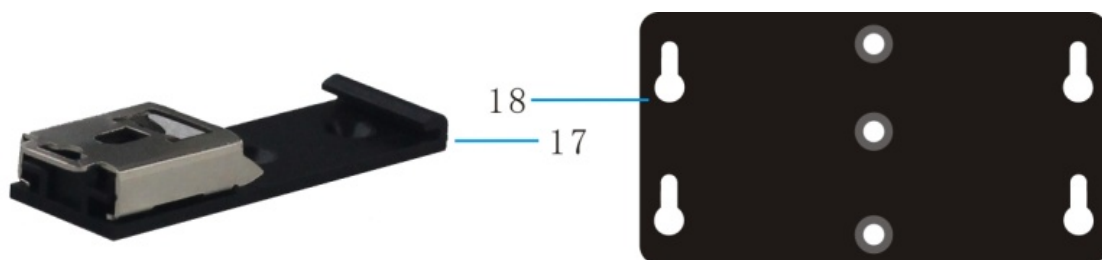

### 3. The panels and LED indicators

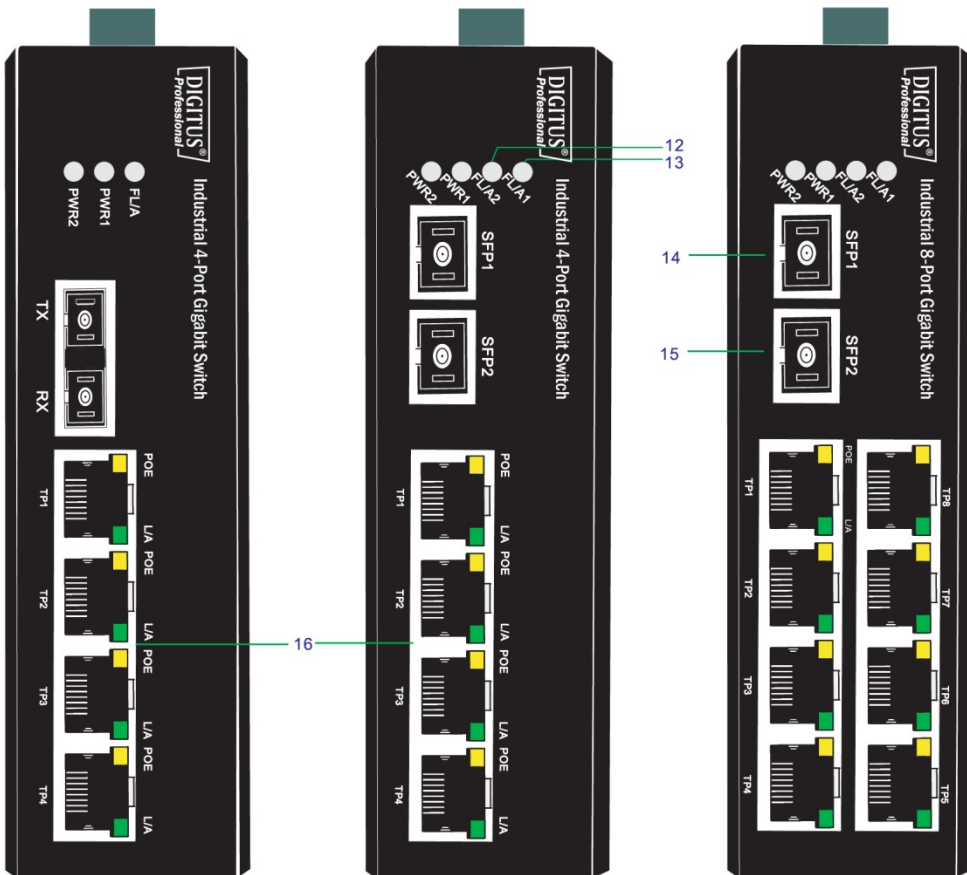
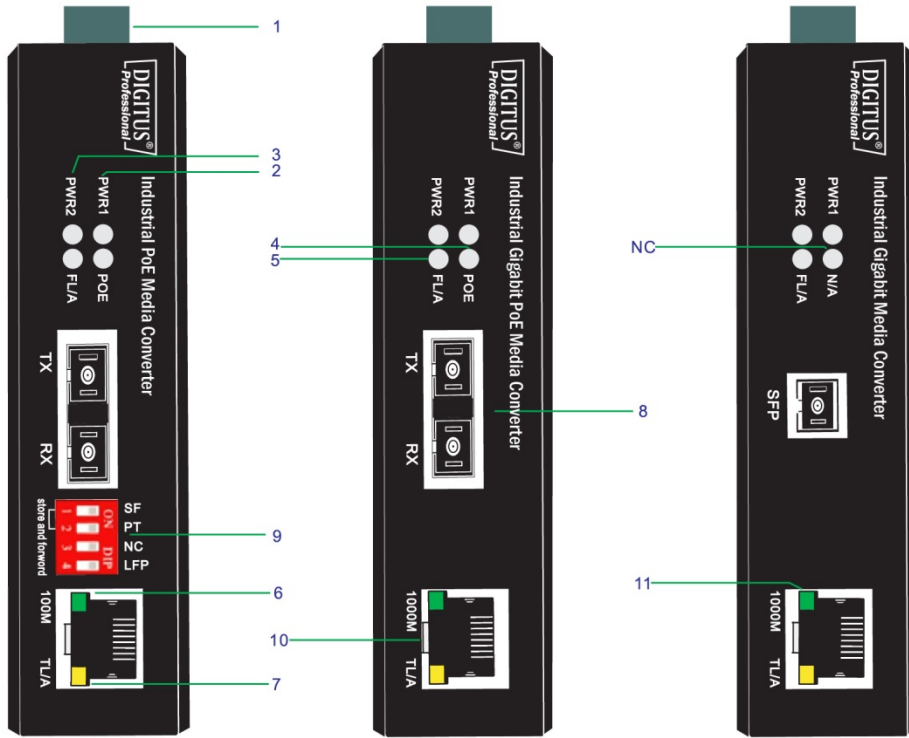

Mark	Name	Function
1	<b>Terminal block</b>	Power supply and Grounding port
2	<b>PWR1</b>	“On”: Power 1 is on and normal
3	<b>PWR2</b>	“On”: Power 2 is on and normal
4	<b>PoE</b>	“On”: Power over PoE port is on and normal
5	<b>FL/A</b>	“On”: Fiber link is in correct connection. “Blink”: Signal packet goes through Fx end
6	<b>100M</b>	“On”: 100Mbps
7	<b>TL/A, L/A</b>	“On”: Electric link is in correct connection. “Blink”: Signal packet goes through Tx end
8	<b>Optical port</b>	Fiber optic connecting port. Connector type: SC, FC, ST, LC
9	<b>DIP Switch</b>	To control the LFP function
10	<b>RJ45 port</b>	Copper cable connector
11	<b>1000M</b>	“On”: 1000Mbps
12	<b>FL/A2</b>	“On”: SFP2 Fiber link is in correct connection. “Blink”: Signal packet goes through SFP2 Fx end
13	<b>FL/A1</b>	“On”: SFP1 Fiber link is in correct connection. “Blink”: Signal packet goes through SFP1 Fx end
14	<b>SFP1</b>	SFP mould port 1
15	<b>SFP2</b>	SFP mould port 2
16	<b>1×4 RJ45</b>	Copper cable connector
17	<b>DIN kit</b>	DIN-rail mounting kit
18	<b>Ear kit</b>	Wall mounting kit
19	<b>N/A</b>	Not applicable

## DIP switch (if available)

Switch	Status	Function
1	On	Pass through mode
	Off	Switch mode
2	On	Modified cut through mode
	Off	Store-and-forward mode
3	On	No available
	Off	/
4	On	Enable LFP function(default)
	Off	Disable LFP function

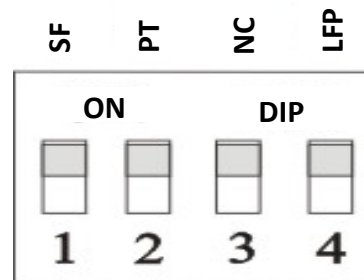

Store and forward

## 4. Installation

### 4.1 DIN-rail installation

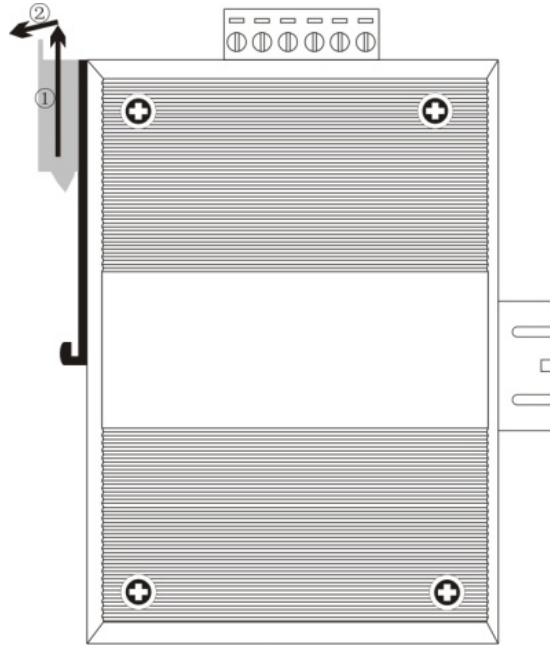

Pic 1

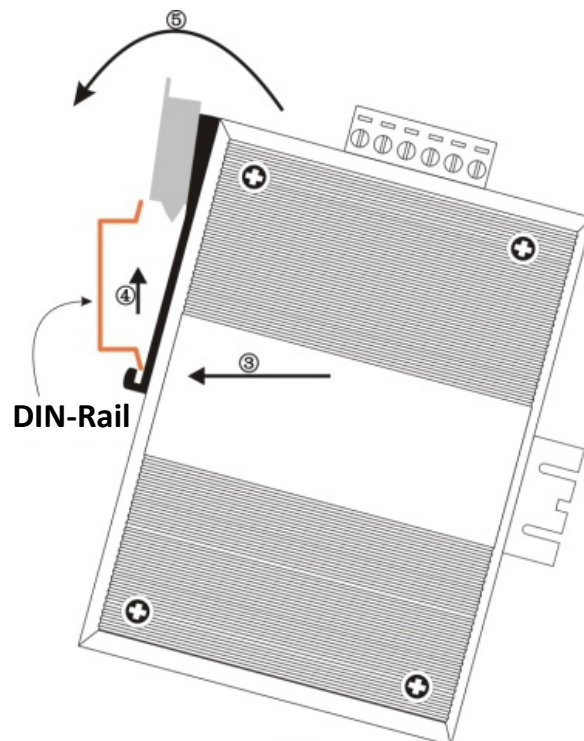

Pic 2

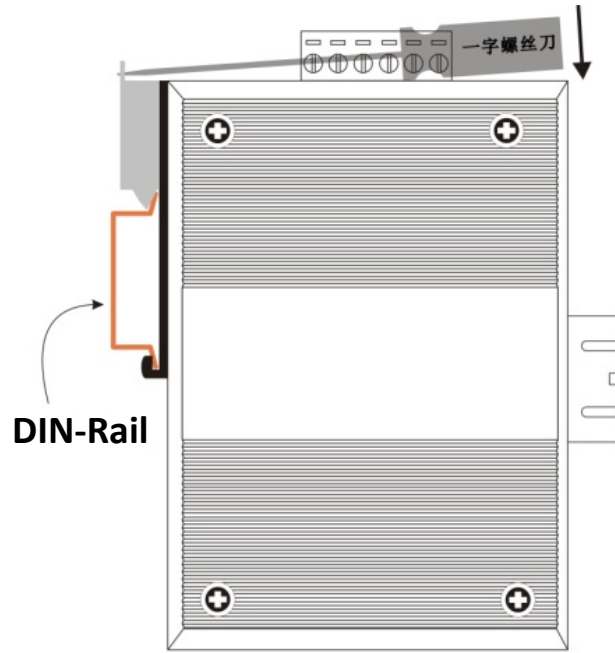

Pic 3

The DIN installation is based on the Pic 1 and Pic 2. Unload is based on the Pic 3, then Pic2 and Pic 1.

## 4.2 Wall-mounted installation

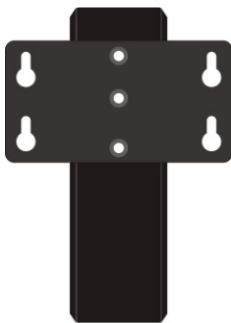

Pic 4

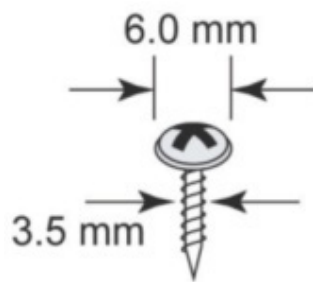

Pic 5

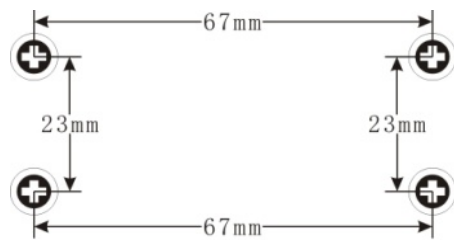

Pic 6

Fix hanging ears in the switch, as shown in figure 4

Select 4 suitable screws (diameter of screw head should be less than 6 mm, diameter of screw should be less than 3.5 mm diameter, as shown in Pic 5) and fix the device on the wall as Pic 6, don't completely tighten the screws, keep some space about 2mm.

Install hanging ear of switch alignment inside the four screws, then press the switch down, ensure the hanging ear has been fixed properly, and turn the screw.

### 4.3 Wall-mounted installation

Input terminal of the switch for 6PIN plug type terminals, V1+ and V1- is for power supply 1 (PWR1), V2+ and V2- is for power supply 2 (PWR2) and GND for earthing terminal, as shown in Pic 7.

Power 1 and power 2 input voltage range is 12VDC ~ 56VDC, V1+, and V2+ are positive, V1- and V2- are negative, and the equipment supports anti reverse function; Two sets of power can be simultaneously accessed. So if one of the power failures, the switch is still able to work.

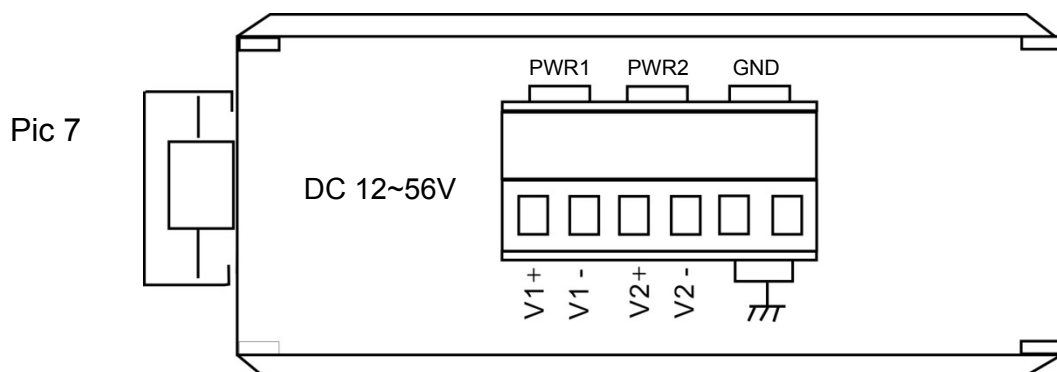

## 4.4 Dimensions

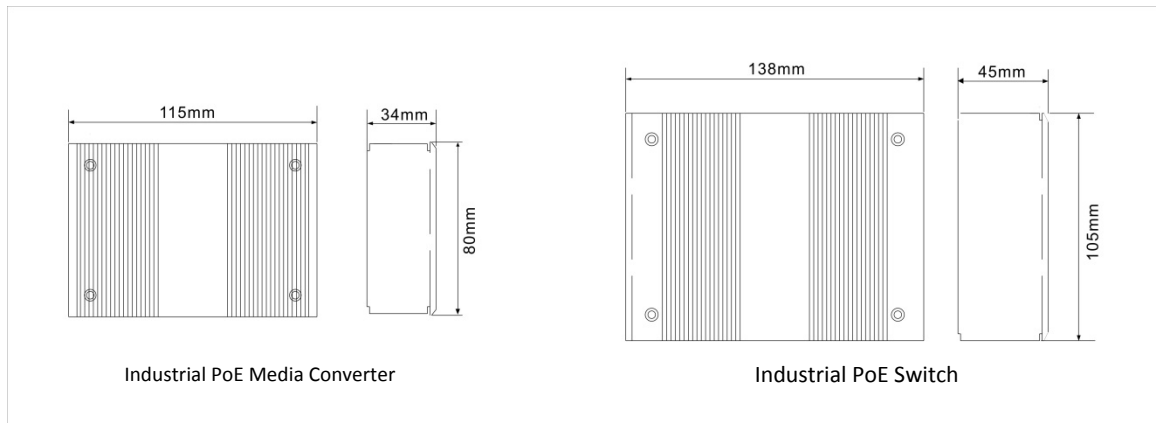

## 4.5 Copper cable connection

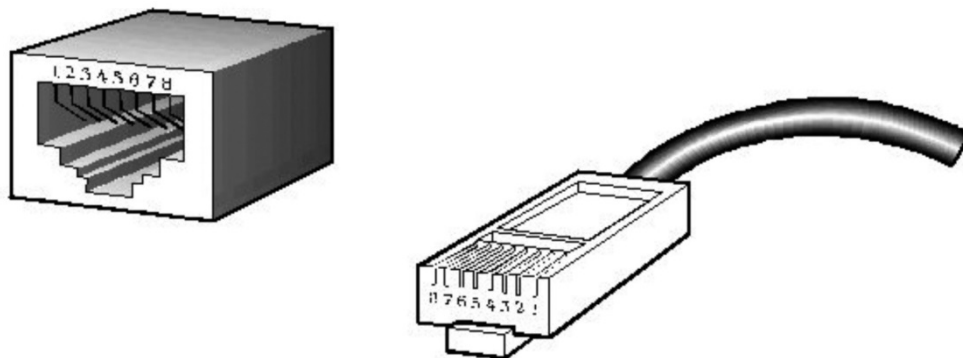

The standard RJ45 receptacle/connector

There are 8 wires on a standard UTP/STP cable and each wire is color coded. The following shows the pin allocation and color of straight through cable and crossover cable connection:



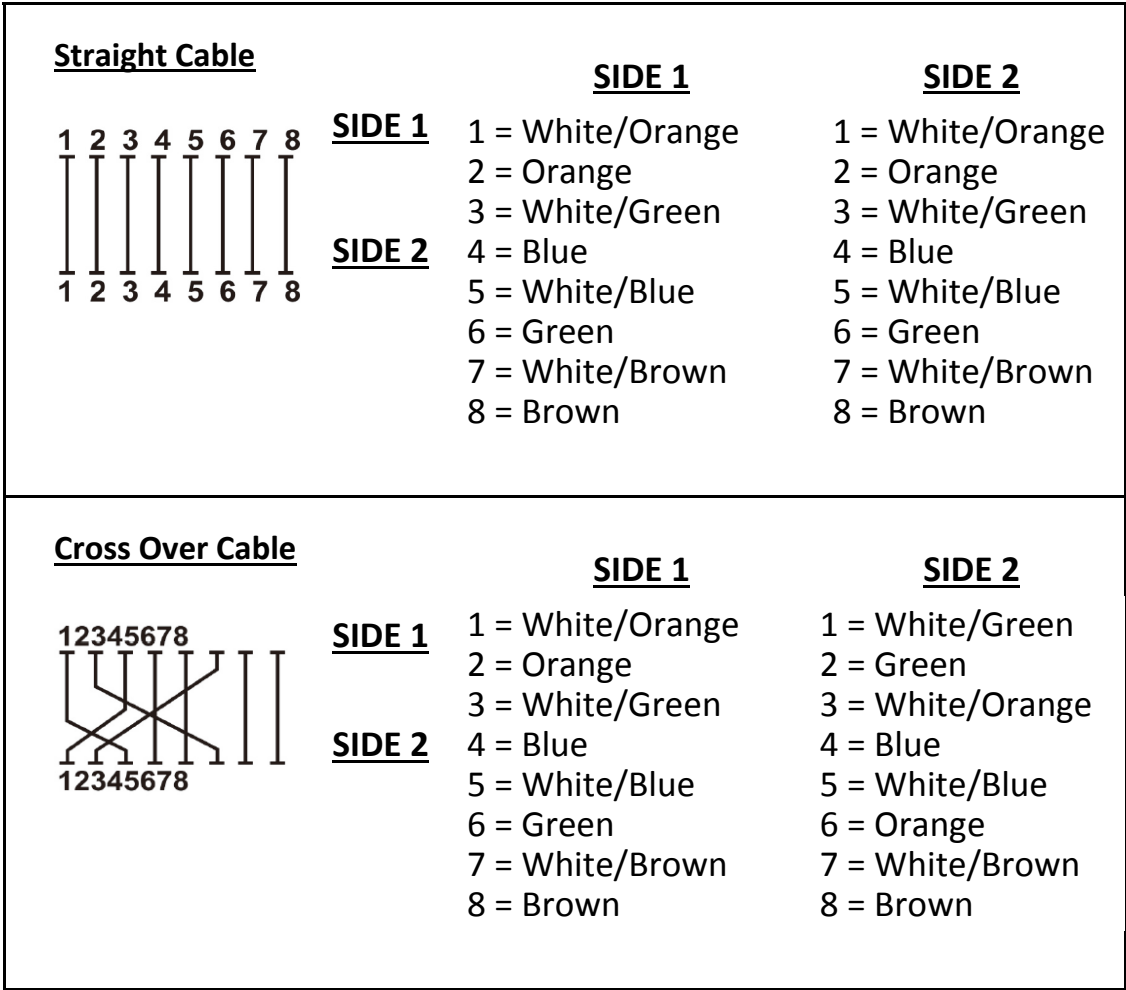

### 4.6 Fiber cable connection

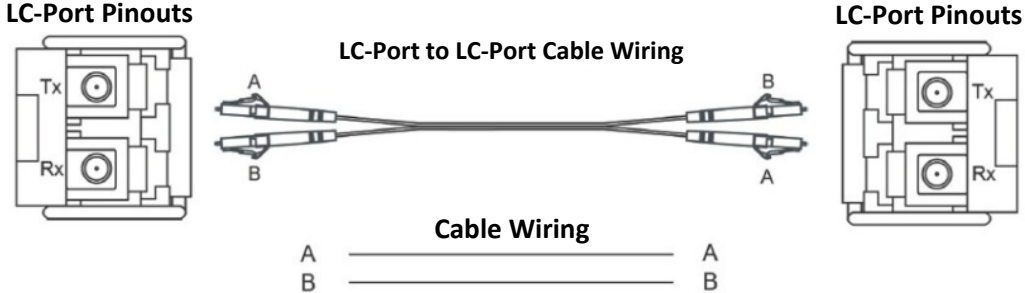

## 5. Technical parameters

- **Power supply**

Input voltage:	12V~56V (redundant dual power)
PSE Power:	0~30W
PoE Pin:	1/2+, 3/6-

- **Copper Port**

Connector:	RJ-45 connector
Data Rate:	10/100Mbps Auto, 10/100/1000Mbps Auto
Twisted Pair cable:	Cat5 UTP cable
Transmission distance:	100 meter

- **Fiber Port**

Connector:	SC (default), FC/ST/SFP (optional)
Data Rate:	155Mbps, 1.25Gbps
Fiber Type:	SM 9/125μm, MM 50/125μm, 62.5/125μm
Transmission distance:	20km ~ 120km

- **Environment**

Storage temperature:	-40~95°C
Operating temperature:	-40~85°C
Relative humidity:	5%-90%

- **Mechanism**

Enclosure:	IP40, Black, Metal shell
Mounting:	DIN-rail, Wall

- **Agreement**

IEEE 802.3, IEEE 802.3u, IEEE 802.3ab, IEEE 802.3z, IEEE 802.3x  
IEEE802.3af, IEEE802.3at

## 6. Warning

- This product is suitable for indoor application.
- Place the dust cover on the fiber interface when not in use.
- It is dangerous to stare at the fiber transmitter with the naked eyes.
- Optical fiber transceivers must be used in pair.
- Single optical fiber transceiver must be used in pair (A, B)  
A: TX1310/RX1550nm  
B: TX1550/RX1310nm

## 7. Trouble shooting

- Device is not connecting. Please check that the corresponding network device is using the same transfer rate as the media converter (10Mbps, 100Mbps or 1000Mbps).
- If power loss is excessive in the fiber, please check and clean the fiber patch cord connectors.

## **8. Responsibility Note**

1. If the end user damages the product which needs to repair or maintain, he/she needs to carry the transportation fee by himself/herself and ship back to our warehouse.
2. Please contact your authorized reseller immediately, if there is any damage to the equipment during transport
3. If you want to prepare power supply by yourself, please make sure the power supply you select meet the requirement given by this manual. We will not cover the damage caused by your using unqualified power supply.
4. Do please follow this manual when using the power supply.
5. All rights reserved. No part of this manual can be reproduced, or transmitted in any form or by any means, without authorization from us.
6. We will not cover the damage to the equipment or any person caused by your changing the equipment or this manual in any form without authorization from us.
7. We will change the equipment for new ones if it cannot work normally because of the quality itself within the warranty time. We will keep the old ones.
8. The packages of the equipment meet the requests of environmental protection, should be recycled.
9. Attention: If there is any mistake of description on the manual, we keep the rights and the authorities to explain the facts. And the pictures of equipment appearance in this manual are just for user's information, the final equipment appearance depends on reality products, if there are any improvements on technology, we will be sorry for won't inform you again.

This is a Class A product. In home environment, this product may cause radio interference. In this case, the user may be required to take appropriate measures.

Hereby Assmann Electronic GmbH, declares that the Declaration of Conformity is part of the shipping content. If the Declaration of Conformity is missing, you can request it by post under the below mentioned manufacturer address.

**[www.assmann.com](http://www.assmann.com)**

Assmann Electronic GmbH

Auf dem Schüffel 3

58513 Lüdenscheid

Germany

